







































Sommario

Composizione bus gamma M6	3
SLOT 3 (H1-CV_)	3
Diagnostica	3
SLOT 4 (H1-CV_)	3
Diagnostica	4
SLOT 5 (H1-I32)	4
Diagnostica	5
SLOT 6 (H1-P32)	6
Diagnostica	7

Composizione bus gamma M6



SLOT 3 (H1-CV_)

A Side	Pin	Nome Name	Descrizione Description	Indirizzo Address	B Side	Pin	Nome Name	Descrizione Description	Indirizzo Address		
	1	1A	+12V	OUT 12Volt		1	1B	+12V	OUT 12Volt		
	2	2A	0V	0V out 12V		2	2B	0V	0V out 12V		
	3	3A	PHA 1	Encoder 1		3	3B	PHA 2	Encoder 2		
	4	4A	-	-		4	4B	-	-		
	5	5A	PHB 1	Encoder 1		5	5B	PHB 2	Encoder 2		
	6	6A	-	-		6	6B	-	-		
	7	7A	Z1	Encoder 1		7	7B	Z2	Encoder 2		
	8	8A	-	-		8	8B	-	-		
	9	9A	I1	Digital inputs (PNP)		9	9B	I5	Digital inputs (PNP)		
	10	10A	I2		X.INP01		10	10B		I6	X.INP05
	11	11A	I3		X.INP02		11	11B		I7	X.INP06
	12	12A	I4		X.INP03		12	12B		I8	X.INP07
	13	13A	COM 1		X.INP04		13	13B		COM 2	X.INP08
	14	14A	O1	Digital outputs		14	14B	O5	Digital outputs		
	15	15A	O2		X.OUT01		15	15B		O6	X.OUT05
	16	16A	O3		X.OUT02		16	16B		O7	X.OUT06
	17	17A	O4		X.OUT03		17	17B		O8	X.OUT07
	18	18A	-	-		18	18B	-	-		
	19	19A	GAO (0V)	Analog output 1		19	19B	GAO (0V)	Analog output 1		
	20	20A	AO 1		X.AN01		20	20B		AO 2	X.AN02

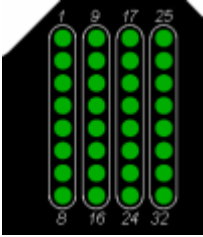
Diagnostica

DIAGNOSTICA	Led n°	Risorsa HW
	1	X.INP01
	2	X.INP02
	3	X.INP03
	4	X.INP04
	5	X.INP05
	6	X.INP06
	7	X.INP07
	8	X.INP08
	9	X.INP49
	10	X.INP50
	17	X.OUT01
	18	X.OUT02
	19	X.OUT03
	20	X.OUT04
	21	X.OUT05
	22	X.OUT06
	23	X.OUT07
	24	X.OUT08
	25	X.CNT01
	26	X.CNT02







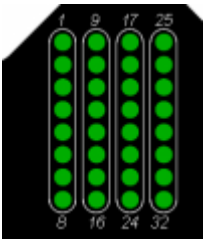



































SLOT 4 (H1-CV_)

A Side	Pin	Nome Name	Descrizione Description	Indirizzo Address	B Side	Pin	Nome Name	Descrizione Description	Indirizzo Address		
	1	1A	+12V	OUT 12Volt		1	1B	+12V	OUT 12Volt		
	2	2A	0V	0V out 12V		2	2B	0V	0V out 12V		
	3	3A	PHA 1	Encoder 1		X.CNT03	3	3B	PHA 2	Encoder 2	X.CNT04
	4	4A	-	-			4	4B	-	-	
	5	5A	PHB 1	Encoder 1		X.CNT03	5	5B	PHB 2	Encoder 2	X.CNT04
	6	6A	-	-			6	6B	-	-	
	7	7A	Z1	Encoder 1		X.INP51	7	7B	Z2	Encoder 2	1.INP52
	8	8A	-	-			8	8B	-	-	
	9	9A	I1	Digital inputs (PNP)		X.INP09	9	9B	I5	Digital inputs (PNP)	X.INP13
	10	10A	I2			X.INP10	10	10B	I6		X.INP14
	11	11A	I3			X.INP11	11	11B	I7		X.INP15
	12	12A	I4			X.INP12	12	12B	I8		X.INP16
	13	13A	COM 1	Common			13	13B	COM 2	Common	
	14	14A	O1	Digital outputs		X.OUT09	14	14B	O5	Digital outputs	X.OUT13
	15	15A	O2			X.OUT10	15	15B	O6		X.OUT14
	16	16A	O3			X.OUT11	16	16B	O7		X.OUT15
	17	17A	O4			X.OUT12	17	17B	O8		X.OUT16
	18	18A	-	-			18	18B	-	-	
	19	19A	GAO (0V)	Analog output 1			19	19B	GAO (0V)	Analog output 1	
	20	20A	AO 1			X.AN03	20	20B	AO 2		X.AN04

Diagnostica

DIAGNOSTICA	Led n°	Risorsa HW
	1	X.INP09
	2	X.INP10
	3	X.INP11
	4	X.INP12
	5	X.INP13
	6	X.INP14
	7	X.INP15
	8	X.INP16
	9	X.INP51
	10	X.INP52
	17	X.OUT09
	18	X.OUT10
	19	X.OUT11
	20	X.OUT12
	21	X.OUT13
	22	X.OUT14
	23	X.OUT15
	24	X.OUT16
	25	X.CNT03
	26	X.CNT04



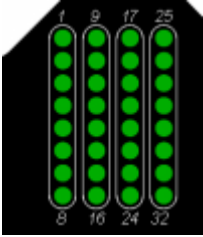

SLOT 5 (H1-I32)

A Side	Pin	Nome Name	Descrizione Description	Indirizzo Address	B Side	Pin	Nome Name	Descrizione Description	Indirizzo Address
	1	1A	+12V			1	1B	+12V	
	2	2A	0V			2	2B	0V	
	3					3			
	4	3A	I1	X.INP17		4	3B	I17	X.INP33
	5	4A	I2	X.INP18		5	4B	I18	X.INP34
	6	5A	I3	X.INP19		6	5B	I19	X.INP35
	7	6A	I4	X.INP20		7	6B	I20	X.INP36
	8	7A	I5	X.INP21		8	7B	I21	X.INP37
	9	8A	I6	X.INP22		9	8B	I22	X.INP38
	10	9A	I7	X.INP23		10	9B	I23	X.INP39
	11	10A	I8	X.INP24		11	10B	I24	X.INP40
	12	11A	+12V			12	11B	+12V	
	13	12A	0V			13	12B	0V	
	14	13A	I9	X.INP25		14	13B	I25	X.INP41
	15	14A	I10	X.INP26		15	14B	I26	X.INP42
	16	15A	I11	X.INP27		16	15B	I27	X.INP43
	17	16A	I12	X.INP28		17	16B	I28	X.INP44
	18	17A	I13	X.INP29		18	17B	I29	X.INP45
	19	18A	I14	X.INP30		19	18B	I30	X.INP46
	20	19A	I15	X.INP31		20	19B	I31	X.INP47
	20	20A	I16	X.INP32		20	20B	I32	X.INP48

Diagnostica

DIAGNOSTICA	Led n°	Risorsa HW
	1	X.INP17
	2	X.INP18
	3	X.INP19
	4	X.INP20
	5	X.INP21
	6	X.INP22
	7	X.INP23
	8	X.INP24
	9	X.INP25
	10	X.INP26
	11	X.INP27
	12	X.INP28
	13	X.INP29
	14	X.INP30
	15	X.INP31
	16	X.INP32
	17	X.INP33
	18	X.INP34
	19	X.INP35
	20	X.INP36
	21	X.INP37
	22	X.INP38
	23	X.INP39
	24	X.INP40
	25	X.INP41
	26	X.INP42
	27	X.INP43
	28	X.INP44
	29	X.INP45
	30	X.INP46
	31	X.INP47
	32	X.INP48

SLOT 6 (H1-P32)

A Side	Pin	Nome Name	Descrizione Description	Indirizzo Address	B Side	Pin	Nome Name	Descrizione Description	Indirizzo Address			
	1	1A	Voltage input 12÷28 Vdc			1	1B	Voltage input 12÷28 Vdc				
	2	2A				2B	V-					
	3	3A	O1	Digital outputs		X.OUT17	3	3B	O17	X.OUT33		
	4	4A	O2			X.OUT18	4	4B	O18	X.OUT34		
	5	5A	O3			X.OUT19	5	5B	O19	X.OUT35		
	6	6A	O4			X.OUT20	6	6B	O20	X.OUT36		
	7	7A	O5			X.OUT21	7	7B	O21	X.OUT37		
	8	8A	O6			X.OUT22	8	8B	O22	X.OUT38		
	9	9A	O7			X.OUT23	9	9B	O23	X.OUT39		
	10	10A	O8			X.OUT24	10	10B	O24	X.OUT40		
	11	11A	V+	Voltage input 12÷28 Vdc			11	11B	Voltage input 12÷28 Vdc			
	12	12A	V-				12	12B				
		13	13A	Digital inputs (PNP)		X.OUT25		13	13B	O25	X.OUT41	
		14	14A			O10		X.OUT26	14	14B	O26	X.OUT42
		15	15A			O11		X.OUT27	15	15B	O27	X.OUT43
		16	16A			O12		X.OUT28	16	16B	O28	X.OUT44
		17	17A			O13		X.OUT29	17	17B	O29	X.OUT45
		18	18A			O14		X.OUT30	18	18B	O30	X.OUT46
		19	19A			O15		X.OUT31	19	19B	O31	X.OUT47
		20	20A			O16		X.OUT32	20	20B	O32	X.OUT48

Diagnostica

DIAGNOSTICA	Led n°	Risorsa HW
	1	X.OUT17
	2	X.OUT18
	3	X.OUT19
	4	X.OUT20
	5	X.OUT21
	6	X.OUT22
	7	X.OUT23
	8	X.OUT24
	9	X.OUT25
	10	X.OUT26
	11	X.OUT27
	12	X.OUT28
	13	X.OUT29
	14	X.OUT30
	15	X.OUT31
	16	X.OUT32
	17	X.OUT33
	18	X.OUT34
	19	X.OUT35
	20	X.OUT36
	21	X.OUT37
	22	X.OUT38
	23	X.OUT39
	24	X.OUT40
	25	X.OUT41
	26	X.OUT42
	27	X.OUT43
	28	X.OUT44
	29	X.OUT45
	30	X.OUT46
	31	X.OUT47
	32	X.OUT48

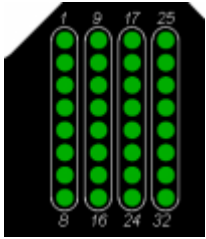

Documento generato automaticamente da **Qem Wiki** - <http://wiki.qem.it/>

Il contenuto wiki è costantemente aggiornato dal team di sviluppo, è quindi possibile che la versione online contenga informazioni più recenti di questo documento.