

Índice



The electrical features are given in section [Electrical features](#).
The example of the connection are given in section [Connection examples](#)

CN23	Terminal	Symbol	Description	Address
	1A	VD1	Internal bridge 1A -1B	
	2A	DIR1+	DIRECTION 1 output	3.PULSE01
	3A	STEP1+	STEP 1 output	
	4A	DIR2+	DIRECTION 2 output	
	5A	STEP2+	STEP 2 output	3.PULSE02
	6A	0V	Stepper outputs common	
	1B	VD1	Internal bridge 1A -1B	
	2B	DIR1-	DIRECTION 1 complementary output	Complementary outputs for use on driver with Line-Driver inputs
	3B	STEP1-	STEP 1 complementary output	
	4B	DIR2-	DIRECTION 2 complementary output	
	5B	STEP2-	STEP 2 complementary output	
	6B	0V	Stepper outputs common	
CN24	Terminal	Symbol	Description	Address
	1A	VD2	Internal bridge 1A -1B	
	2A	DIR3+	DIRECTION 3 output	3.PULSE03
	3A	STEP3+	STEP 3 output	
	4A	DIR4+	DIRECTION 4 output	
	5A	STEP4+	STEP 4 output	3.PULSE04
	6A	0V	Stepper outputs common	
	1B	VD2	Internal bridge 1A -1B	
	2B	DIR3-	DIRECTION 3 complementary output	Complementary outputs for use on driver with Line-Driver inputs
	3B	STEP3-	STEP 3 complementary output	
	4B	DIR4-	DIRECTION 4 complementary output	
	5B	STEP4-	STEP 4 complementary output	
	6B	0V	Stepper outputs common	

STEP-DIRECTION voltage settings

CN25	Terminal	Simbol	Description	Address	
	1A	VD3	Internal bridge 1A -1B	3.PULSE05	
	2A	DIR5+	DIRECTION 5 output		Push-Pull Line Driver
	3A	STEP5+	STEP 5 output		
	4A	-	n.c.		
	5A	-	n.c.		
	6A	0V	Stepper outputs common		
	1B	VD3	Internal bridge 1A -1B	Complementary outputs for use on driver with Line-Driver inputs	
	2B	DIR5-	DIRECTION 5 complementary output		
	3B	STEP5-	STEP 5 complementary output		
	4B	-	n.c.		
	5B	-	n.c.		
	6B	0V	Stepper outputs common		

STEP-DIRECTION voltage settings

With JP1 to JP9 jumper, you can set the nominal voltage of the STEP and DIR outputs.

For each connector should be inserted only one bridge at a time
If you select one of the two voltages 5V(JP3,JP6,JP9) or 12V(JP1,JP4,JP7) the 1A and 1B terminals must be disconnected

	Name jumper	Setting	Nominal voltage
	JP1	INSERTED	12V (voltage supplied by the device)
	JP2	INSERTED	VD1 (Voltage to be supplied to terminals 1A or 1B)
	JP3	INSERTED	5V (Voltage supplied by the device)
	JP4	INSERTED	12V (voltage supplied by the device)
	JP5	INSERTED	VD2 (Voltage to be supplied to terminals 1A or 1B)
	JP6	INSERTED	5V (Voltage supplied by the device)

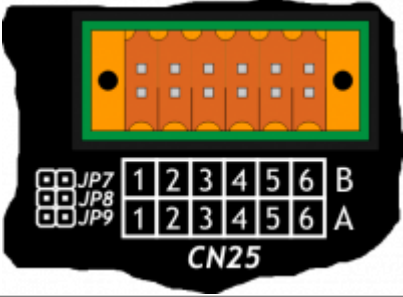
	Name jumper	Setting	Nominal voltage
	JP7	INSERTED	12V (voltage supplied by the device)
	JP8	INSERTED	VD3 (Voltage to be supplied to terminals 1A or 1B)
	JP9	INSERTED	5V (Voltage supplied by the device)

	+12V	JP1,JP4,JP7
	VDx	JP2,JP5,JP8
	+5V	JP3,JP6,JP9

Documento generato automaticamente da **Qem Wiki** - <https://wiki.qem.it/>

Il contenuto wiki è costantemente aggiornato dal team di sviluppo, è quindi possibile che la versione online contenga informazioni più recenti di questo documento.